



The Flightline



Volume 44, Issue 1 Newsletter of the Propstoppers RC Club AMA 1042 January 2014



President's Message

I hope you have all had a successful flying year in 2013. I think the club activities were successful and we are going from strength to strength with new members steadily joining and adding new avenues to club flying.

Please note the dates for the remaining indoor meets. The first one at Tinicum was successful but lightly attended but the following Brookhaven meet was very well supported. Chuck Kime is to be thanked for organizing the flying so all members may enjoy their particular field.

I hope to see you all at the January monthly meeting, be prepared to renew you membership and bring your Show and Tells. Wishing you all a Happy New Year,

Dick Seiwel, President

Agenda for January 14th Meeting At Middletown Library; Doors open 6:00, meeting at 6:30

1. Show and Tell
2. Membership Report
3. Finance Report

There are no Minutes of the Propstoppers Model Airplane Club from the December meeting because it was cancelled due to bad weather.

INSIDE THIS ISSUE

- 1 *President's Message*
- 1 *December Meeting Cancelled*
- 1 *January Meeting Agenda*
- 1 *Where Next With Quads?*
- 1 *Indoor Program Schedule*
- 6 *The Octdeca*
- 9 *Another Way to Launch Your Glider*
- 10 *Heat Engines, Part II*
- 16 *Lebanon Swap Meet*
- 16 *The SR-71; How Slow Could It Fly?*
- 18 *Membership Renewal Form*

2013/14 Indoor Flying

Mike Black has once again secured the Tinicum School gym for indoor flying. The dates are;

January 3, 2014	6:30 – 9:30 PM
February 7, 2014	6:30 – 9:30 PM
March 7, 2014	6:30 – 9:30 PM

Brookhaven; Saturday nights 6:30 till 9:30 PM
 Jan 18 2014
 Feb 15 2014

Where Next With Quads?

With all the wonderful Quad technology out there surely someone could build some scale models, or models of concepts that have been pursued. The first one that comes to mind is the Curtiss Wright XV-19.

http://en.wikipedia.org/wiki/Curtiss-Wright_X-19

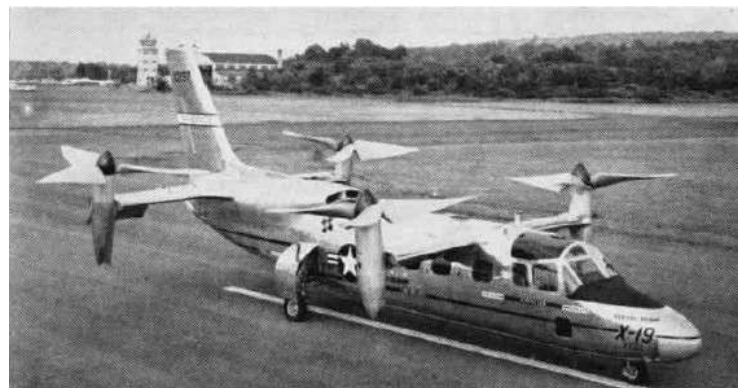

This airplane relies on a propeller force known as a P factor to make it work in the transition mode when the props are canted to the incoming airstream. There are a number of different P Factors. The one most familiar to modelers is that which is encountered in takeoff of a tail dragger propeller driven airplane. In the US, where props rotate clockwise when viewed from behind the airplane turns left due to

Calendar of Events

Club Meetings

Monthly Meetings
Second Tuesday of the month.
Middletown Library
Doors open at 6:00, meeting at 6:30 pm.
Next Meeting; 14th January

Tuesday Breakfast Meeting
Tom Jones Restaurant on Edgemont Avenue in Brookhaven. 9 till 10 am. Just show up.
Flying after in the summer at CA or Elwyn Field 10 am. Weather permitting.

Regular Club Flying

At Christian Academy; Electric Only
Monday through Friday after school till dusk
Saturday 10 am till dusk
Sunday, after Church; 12 pm till dusk
At Elwyn Field; Gas or Electric
Monday through Saturday 8 am till dusk
Sunday 12 pm till dusk

Indoor Flying

See page 1

Special Club Flying

Saturday mornings 10 am
Wednesday Helicopter evening in summer
Thursday evenings in the summer
Tuesday mornings 10 am weather permitting after breakfast.

Check our Yahoo Group for announcements;
<http://groups.yahoo.com/group/propstoppers/>

Beginners

Beginners using due caution and respecting club rules may fly Apprentice or similar models without instructors at Christian Academy Field.
The club also provides the AMA Introductory Pilot Program for beginners without AMA insurance.

differential thrust on right and left blades. The XV-19 utilizes the Lift P Factor which under the same conditions produces a vertical "lift" force

Propeller "P" Factors

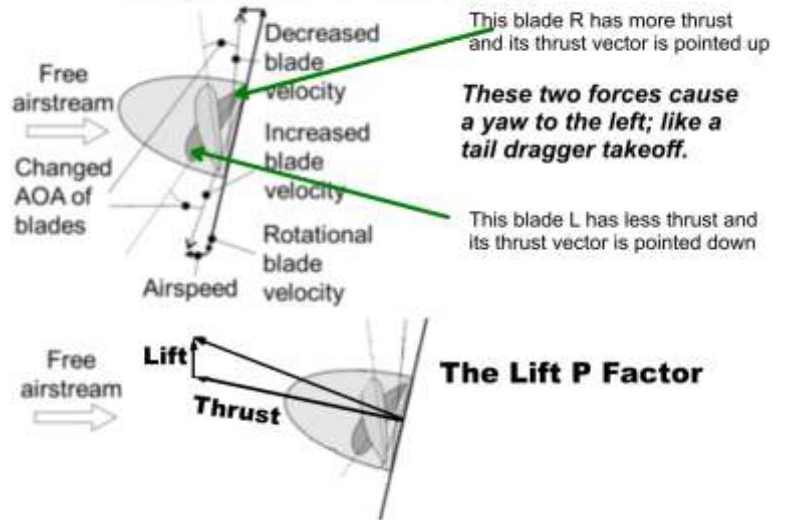

Another Quad from that period was the Bell XV-22. This one used ducted fans rather than propellers.



Propstoppers RC Club of Delaware County, Pennsylvania. Club Officers

President Dick Seiwell reslawns@verizon.net
(610) 566-2698
Vice President Jeff Frazier jfrazier@comcast.net
(610) 357-4557
Secretary Richard Bartkowski rbartkowski@comcast.net
(610) 566-3950
Treasurer Pete Oetinger
610-627-9564
Membership Chairman Ray Wopatek raywop@gmail.com
(610) 626-0732
Safety Officers
Eric Hofberg bgsteam@comcas.net
Ryan Schurman throttle152@hotmail.com
(610) 565-0408
Newsletter Editor davejean1@comcast.net
Dave Harding
(610)-872-1457

Propstoppers Web Site; www.propstoppers.org

Material herein may be freely copied for personal use but shall not be reproduced for sale.



Although this airplane was not a success in terms of leading to production it was used for many years by the Cornell Aeronautical Laboratory as a VTOL aircraft variable stability simulator. Its controls could be altered to simulate an aircraft with a very different configuration, and did so very successfully.

As the V-22 Osprey program moved into production Bell became interested in a V-22 based Quad using two V-22 wing/prop assemblies. Indeed in 2005 the Bell Boeing team was awarded a contract to further explore the idea.





http://en.wikipedia.org/wiki/Bell_Boeing_Quad_TiltRotor

So what do you think you Quad innovators? Can you build one that will transition to propeller mode forward flight? Here is the plan;

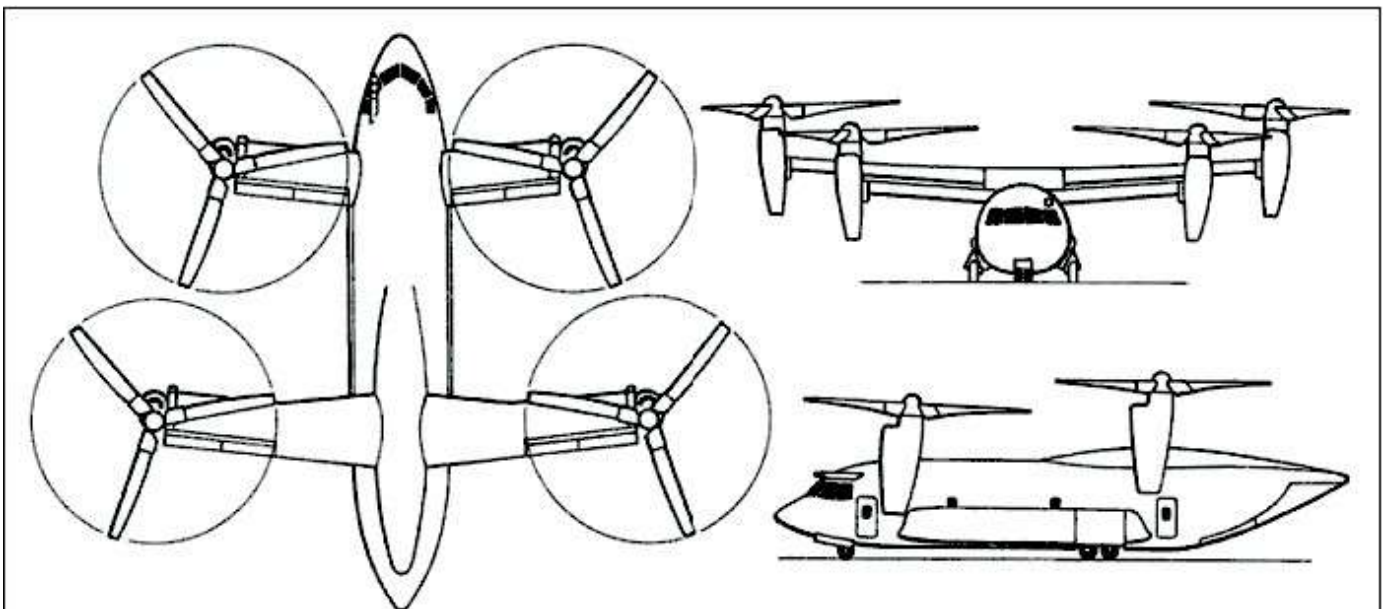

Quad VTOL Concept | Common Sense | 2010



Yikes, someone is already on it. This is the Common Sense RC Predator.

https://commonsenserc.com/product_info.php?cPath=45&products_id=4283&osCsid=gqncgrsfn280d83bgavd6b071

Well, maybe it is not completely along the lines I propose but it looks cool in flight and for \$79 you could be up and running at the next indoor.

Watch the video; <https://www.youtube.com/watch?v=UCM3SUEbLPA#t=20>



But Wait; Now there is the Octdeca

<http://www.dailymail.co.uk/news/article-2529542/Dont-forget-charge-Worlds-electric-two-seater-helicopter-makes-maiden-flight-soon-sale-UK.html>

With its white spiderweb design and 18 rotors humming gently, it looks like it was plucked straight from a science fiction book. This is the world's first electric two-seater helicopter, which could soon be flying over your house after online investors raised £1 million in just three days.

Instead of a traditional combustion engine, it uses a battery pack on the back of the aircraft to power the 18 rotors arranged on top.

Sci-fi: With its 18 rotors and spiderweb pattern, the Volocopter looks like it was plucked from fiction



Eco-friendly: It is the world's first two-seater helicopter to be powered purely by electricity, and much quieter

When completed the Volocopter will be able to fly up to 6,500ft weighing not more than 450kg

Flight of fancy: Although the maiden flight was unmanned, the inventors hope to get people on board soon



Its inventors say it will be the most environmentally-friendly helicopter ever created. They also claim it will be the world's safest because it is unlikely to crash if a rotor fails. The design is so unusual that authorities in Germany, where it is being developed, have had to invent a new class of aircraft for it to get a license to fly.



After the successful test flight last month, inventors Thomas Senkel, Alexander Zosel and Stephan Wolf put out an online plea before Christmas for money from internet investors.

Their 'crowdfunding' attempt on the website seedmatch.de was so successful it smashed all records in Germany - earning them 500,000 Euros in just two and a half hours.

By the time they reached their total of 1.2 million Euros (£1m) in three days, nine hours and 52 minutes, they had been handed money by 750 different investors ranging from 250 to 10,000 Euros.

Engineering: The team in Karlsruhe has taken several years and millions of Euros to advance the design this far. Mr Zosel, the managing director of E-Volo, the firm behind the aircraft, said: 'There are already numerous requests for the Volocopter from around the world. 'The money raised will now serve to optimize the first prototype of the VC200 and, as part of the testing scheme, conclude a comprehensive test flight program for this new aviation category. After that, we will build a weight-optimized prototype of the VC200 [to prepare for mass production]. 'With multiple flights lasting several minutes reaching the nearly 22m [72ft] high ceiling, including a number of smooth takeoffs and landings, the Volocopter concept exceeded all expectations.

The idea has been several years in the planning and previously won a 2 million Euro (£1.7m) grant from Germany's federal ministry of economics and technology.

Test flights were conducted in Karlsruhe, Germany, including of a 16-rotor prototype last year with room for just one brave pilot.



Weighing just 80kg including the batteries, it was so small that the helmet-wearing pilot had to sit in the open air between the blades strapped into a tiny chair.

Anyone with a private pilot's license in Germany will be able to fly the revolutionary aircraft once it hits the mass market. Its inventors claim it is also simpler to fly than a traditional helicopter, with just one joystick controlling almost every aspect of flight.

The project has been handed a provisional airworthiness certificate and its inventors hope it will get the sign-off from aviation authorities in the near future.

A statement by the firm said: 'The Volocopter is an absolutely novel aircraft which cannot be assigned to any existing aviation category.

'The greatest challenge after technical realization is to be able to place such an aircraft on the market.

Dave Harding

Another Way to Launch Your Glider

The Buzz is that if you are tired of all that fruitless galloping, you have only to get out your Bungee, and.....PING your glider effortlessly up into the wide, blue yonder... but there is ANOTHER WAY!

In faraway Mauritius, home of tropical inventiveness, we do it by:-
Helicopter Lift!



How did it get up there?



the real life photos of Dick Twomey's APS SNARK,
which has made several dreamy flights in this way!
(Who says that R/C can't be useful?)

Dick Twomey

Tech Note - Heat Engines Part II

This is part II of an article I wrote some years ago following a trip to the UK. Since the club is once again flying with internal combustion engines I thought the newer members might be interested. If anyone is interested I am prepared to write part III on the technical side of these developments.

Dave

One of the fun things to do in a museum is to see how inventors coped with specific design problems over the ages. So, since I was once again in London (bringing our Pasadena daughter back home again) I took the opportunity to revisit the Science Museum and to visit the Imperial War Museum's Duxford annex, but more of that for a future time.

Anyway, at Duxford, in the American Air Museum, I stumbled upon Curtis CX5, Liberty and Merlin engines as fitted to various American airplanes. Further on there were many other engines from different eras so I decided to go back to the Science Museum and start with the Wrights.

Just thirty years after Nicolas Otto invented the four stroke internal combustion engine the Wright brothers thought that the last of their problems would be acquiring a lightweight engine for their Flyer. Wrong! So, being the Wright brothers, they just designed and built one.....in a couple of months!

The primary concern in designing an aero engine is to provide sufficient strength to contain the "explosion" (very rapid burning actually) that takes place in the cylinder between the piston and the combustion chamber. The force developed is, naturally, what we are looking for to turn the crank, but the crank support, crankcase, and the cylinder head must react these forces. In an aero engine it is important to provide the necessary strength at the absolute minimum weight. There are many different ways of attaching these parts to achieve this end.

The Wrights approach was novel for the time; in fact it has been rarely copied. They cast a single piece engine block in aluminum. This part contained the crank supports and cylinders, which were screwed-in steel liners, as well as the cylinder head. The crankshaft was slid into the block from the end. The loads were therefore taken totally within this casting, which also provided the liquid cooling jackets around the cylinders like in a modern car. Differing from modern car practice was the actual combustion chamber and valve gear. The Wrights designed a single piece part for each cylinder comprising the combustion chamber, a cam-pushrod-and-rocker actuated exhaust valve and an automatic inlet valve

The Wright Flyer Engine

Thin aluminum crankcase covers removed here

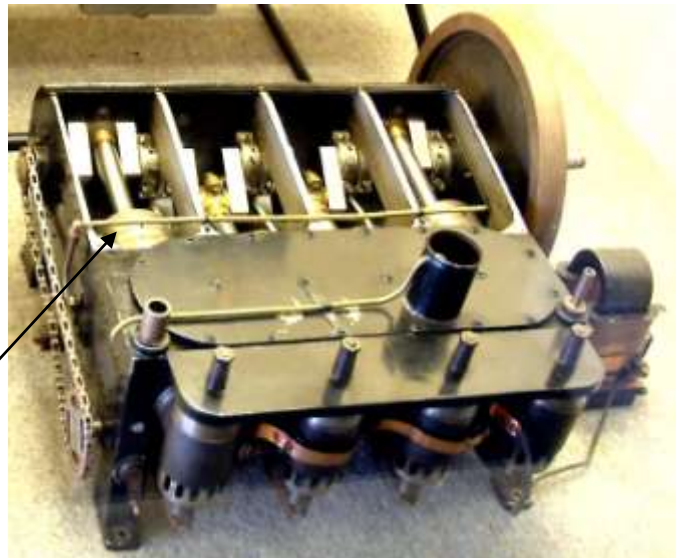

The automatic inlet valve was common in early days. It operated by the vacuum in the cylinder pulling the valve against a soft spring. Closing was also by the internal cylinder gas pressure pushing on the valve.

In their clever design the combustion chambers with valve assemblies were a separate component screwed or bolted to the top of the cylinder assembly.

Notice, the Wrights used chain-driven high mounted camshaft acting directly on the rocker arms. Spark ignition was continuous, not timed, allowing the plugs to be gang-fed by a copper strip.

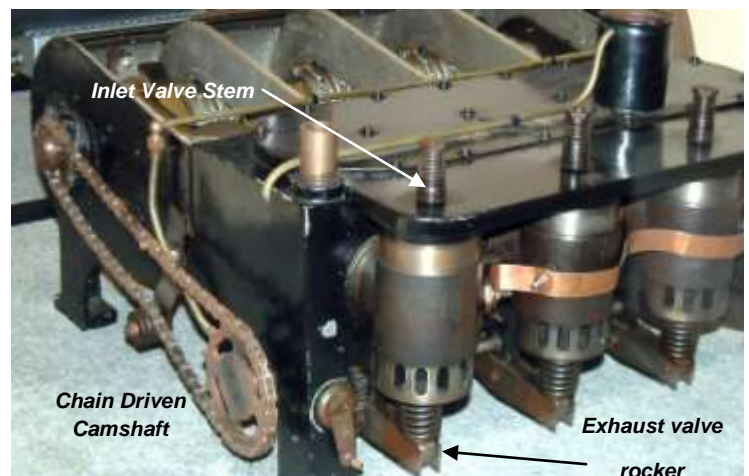

Many early designers realized that the V cylinder arrangement allowed you to put about twice as many cylinders on the same length crankshaft thereby saving weight.

Here is a V8 Antoinette engine that also features cam driven exhaust valves and automatic inlets.

Eventually, designers discovered that the inertia in the gas, which has to very quickly enter and exhaust from the cylinder, needed to be encouraged to leave early. So mechanical control of both inlet and exhaust valves incorporating early opening was required.



This close-up of one bank of cylinders on an air-cooled 1916 Renault 80hp V8 shows the cam driven inlet over exhaust, IOE, arrangement. It allows control over the opening timing of both valves but the combustion chamber shape is poor, limiting the compression ratio and thereby power.



Another great problem for early engines was the sealing of the high-pressure exhaust gasses in the cylinder. This seal had to be maintained when the engine was cold and hot so expansion of the mechanical parts was a big consideration, particularly in engines that used full-length studs to hold separate cylinder and head assemblies like the Renault. Leaks would readily occur at the joint between the cylinder and cylinder head.

The Wright's design minimized these problems by using a one-piece cylinder/block and head assembly. Their sealing surface was the threaded joint between the block and integrated combustion chamber assembly.

The Antoinette engine features short studs to connect the cylinder to the crankcase and another set to attach the head to the cylinders, like a Harley Davidson. The problem with this approach is that the cylinder takes all the loads from combustion. Many are the broken cylinders I have seen at the bike drags when too much nitro is used.

Many engines, then and now, use an integral cylinder and head design. The modern (?) Lycoming engines use a cylinder head that is screwed to the top of the cylinder. Those designs with a truly integral cylinder head suffer from limitations in design of the combustion chamber and valve design. You must be able to make and assemble it.

Of course you know that to grind the valves on a '20's fixed head Bugatti you first have to remove the rear axle then drop the crank and pistons to gain access!

Curtis's early engines were exceptionally efficient; indeed this was probably his great contribution to early aviation.

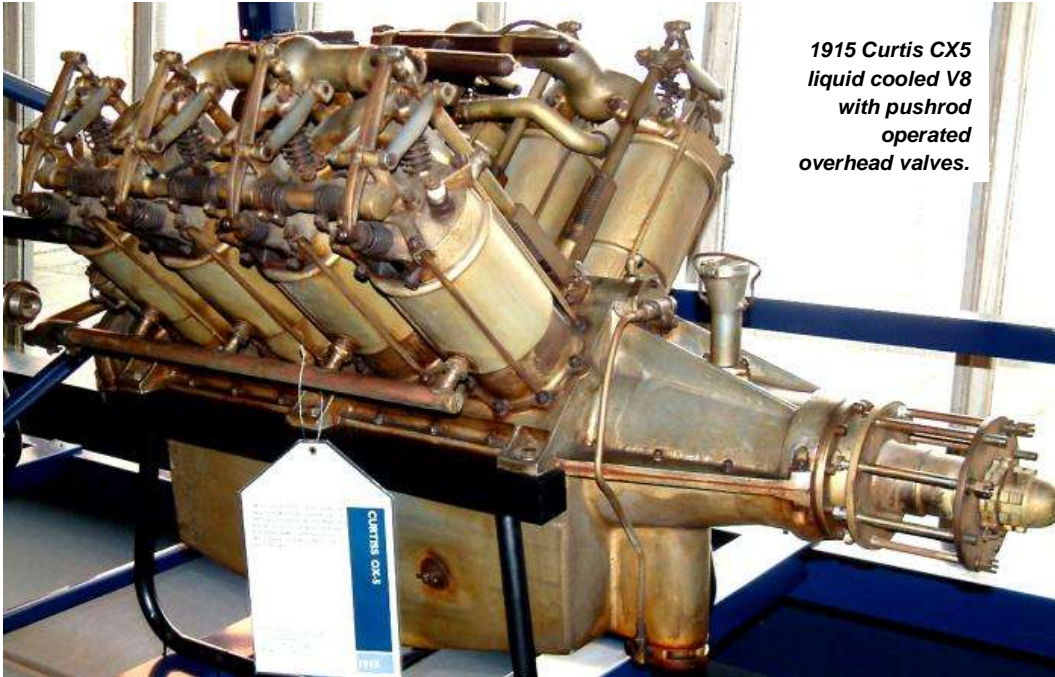

**1915 Curtiss CX5
liquid cooled V8
with pushrod
operated
overhead valves.**

As engines improved it became obvious that aerodynamic and thermodynamic efficiency was important to lightweight fuel-efficient engines. Make them efficient and they will be smaller and lighter for the same output.

The Curtiss OX5 of 1915 featured an efficient combustion chamber and good placement and control of valves. It has two inclined valves in a hemispherical combustion chamber driven by pushrods and rockers from a single camshaft. The cylinder is attached by long through studs and an additional set of short cylinder base studs.

Most of these early engines had exposed valve gear so lubrication of the valves and rockers was poor. They also mostly used welded-on water jackets. This was light but subject to cracking and corrosion. It was one of the shortcomings of the US Liberty V12 engine of 1918 that featured integral heads and cylinder base studs. Much of the valve gear was enclosed for better lubrication and cleanliness and an overhead camshaft was used which allowed for a much more rigid valve train impervious to thermal expansion problems.



**1918 liquid cooled Liberty
V12 cylinder assembly**

The 275 hp Rolls Royce Eagle of 1918 had a similar configuration to the Liberty V12 with two inclined valves in a hemispherical combustion chamber operated by a single overhead cam and exposed rockers.



Development of this basic architecture proceeded through the 1920's and 30's. As materials and fuels improved the output of these engines soared. Power developed went from 300 hp+ in 1918 to over 2000hp in the early 1930's Supercharging in various forms enhanced the power levels and maintained it to higher altitudes.

In Rolls Royce's case much augmented by participation in the Schneider Trophy races. http://en.wikipedia.org/wiki/Schneider_Trophy In 1931 the final contest featured the Supermarine S-6B with a 2,350 hp version of the [Rolls-Royce R](#) V-12 engine. It set the World Speed Record of 407.5 mph, an astonishing development from the WWI era speeds in just 14 years.

These engine developments led directly to the Rolls Royce Merlin which was so successful in WWII airplanes including Hurricane, Spitfire, P-51, Lancaster and many others.



The Merlin cylinder / piston / combustion chamber and fully enclosed four valve twin overhead cam valve gear with removable cylinder heads, shown here, was the standard at the beginning of WWII. Indeed, it is the standard for our automobiles of the new millennium!



Perhaps the height of wretched excess in this line of development was the H-24 arrangement of the Napier Sabre that powered the Hawker Typhoon and Tempest.



Of course there were engines of different configuration! But that is another story for another time.

Dave Harding



Learning how to optimize engine efficiency

Editor's Note: A huge amount of internal engine technology has flourished over the seven decades since the development of the WWII aero engines. But the basic physics is unchanged. What is happening however is the scientists, engineers and designers are squeezing the envelope in every direction. This article, from the SAE journal, highlights some of the developments we may see in the near future



Additional Note:
The Homogenous Charge Compression Ignition is what we do in our model Diesel Engines. I owned my first diesel engine in 1949; an ED Comp Special.
What goes around comes around, so to speak!

Fiat's production MultiAir system proves a combination of advanced engine technologies can improve overall engine efficiency, particularly in reducing pumping loss.

Acronym	Technology	Notes
DI	Direct Injection	Injecting fuel directly into the combustion chamber rather than the intake runner
HCCI	Homogenous Charge Compression Ignition	Can be applied to a number of fuels, if used with gasoline provides better fuel economy
VCT	Variable Cam Timing	Adjusts the timing on all valves attached to a single cam
VVT	Variable Valve Timing	Adjusts the timing on all valves on an individual basis
VCR	Variable Compression Ratio	Adjusts the compression ratio of an engine during operation to achieve maximum thermal efficiency
DoD	Displacement on demand	Shuts down cylinders in an engine when not needed, typically at highway cruise. Sometimes called Active Fuel Management, Variable Cylinder Management.

The growing list of advanced engine technologies needs a guide to the acronyms that help define them.

Engineering engines for optimum efficiency is more important to automakers than ever before, as fuel economy and emissions regulations intensify. To deliver better engines, designers have access to more gadgets—some old, some new—than ever before.

"It is an alphabet soup of tools one can use," admits Dr. W. Mark McVea, Chief Technology Officer for **Torvec** and an instructor for **SAE International**. These advanced engine components include VCT, VVT, VCR, DI, DoD, and HCCI (see table for full description).

Tools, combinations, and systems

"What is important is that these tools are often best used in combination with each other. In many cases, some are enablers for others," Dr. McVea explained. As each of these components becomes more complex as technologists and suppliers refine them, they provide more benefit to the end user through their ever increasing complex interactions. It is essential to find the right set of components to get the best system performance.

This means engine designers must evolve into systems engineers—to fully understand both the parts (the gadgets) as well as the complete engine. But it's not just the engine systems engineer who needs to know details about these tools and gadgets.

"Each component engineer needs to know how other tools work to best optimize their individual pieces," he said, explaining why an injector supplier, for example, might need to know the basics of variable valve timing (VVT) or what goes into designing a variable compression ratio (VCR) engine.

Unlocking the HCCI door

With political pressure on better fuel economy and fewer emissions, the automotive world has been treated to gasoline supplies that are cleaner and more consistent. This, according to Dr. McVea, will lead to better fuel economy for a couple of reasons. First, engine designers can tune existing technology better without accounting for as much variability in the fuel.

"It also opens the door to HCCI," he said, referring to the acronym for homogenous charge compression ignition, a combustion technique that promises diesel-like fuel efficiencies with gasoline. "Previously, the variability in fuel supplies made it too hard to control HCCI, making it impractical," he explained.

Dr. McVea notes the technology for HCCI has evolved from asking the question, "Can we make a new HCCI engine?" to "How can we most effectively use HCCI?"

"We now know that HCCI is good for midrange power," he noted, but it's not as practical or efficient for when the engine is operating at low and high rpm, where spark ignition has been employed on many HCCI engines currently in development.

Key enablers improve

As certain technologies improve, such as VVT or DI, previously difficult engine architectures become more feasible. "For example, the Holy Grail of engine optimization is the combination of VCR and VVT, where VVT is a key enabler," he said. That's because conventional gasoline engines avoid knock by limiting compression ratios to about 12:1. However, this limitation is overly strict at most engine speeds. The 12:1 limit is to ensure safe operation at all speeds and loads. If a device could be invented for adjusting the compression ratio, even better fuel economy could be realized.

Computer control and variable combustion chamber geometry, along with VVT to ensure optimum intake and exhaust, are making VCR more practical. Another example is direct injection, which HCCI requires.

To learn more, Dr. McVea teaches an SAE International seminar titled "Internal Combustion Systems: HCCI, DoD, VCT/VVT, DI, and VCR," ID# C0613 (<http://training.sae.org/seminars/c0613/>).

Bruce Morey

**34TH ANNUAL Lebanon, PA RC FLEA MARKET.
3/8/2014**

Sponsor: CENTRAL PENN AEROMODELERS

Site: Lebanon Expo 80 Rocherty Rd. Lebanon, Pa.

Larry Leiphart CD PH: 717-412-8579 Email: info@cpaa.us.
Visit: www.cpaa.us.

Over 600 indoor table spaces are available in 41000sq ft.
Aisle space \$15 ea, wall space \$20 ea.
General Admission at door is \$8 (830am).
Advance General Admission tickets are available \$7 (8:30).
Call Larry.
First time renters email or call Larry before ordering space(s).
For info, visit website or Larry.

**CENTRAL PENN
AEROMODELERS ASSOC.**
Visit our website at www.cpaa.us

**34th Annual Radio Control
FLEA MARKET**

PLACE: LEBANON FAIRGROUNDS
80 Rocherty Road
Lebanon, PA 17042

DATE: SATURDAY March 8, 2014
(Regardless of Weather)

TIME: 8:30 A.M. for General Admission
7:00 A.M. for Renters Only
Open 'Til 3:00 P.M.

**For table availability
e-mail info@cpaa.us**
Advanced general admission
tickets available at \$7.00
each (www.cpaa.us)

Space
Reservations and
Advanced tickets
Recommended

For advanced tickets visit
www.cpaa.us
(subject to CPAA) to:
CPAA
139 Lee Ann Ct.
Enola, PA 17025

Admission: \$8.00 (General Admission) \$10.00 (Renters Only)
Aisle Spaces: \$15.00 each (2 ft. long)
Wall Spaces: \$20.00 each (3 ft. long)

For Information: Call Larry (717) 412-8579
or email: info@cpaa.us

Baffle Prices Include 2.4 GHz Computer Radio

**LARGEST ONE DAY R/C FLEA MARKET
IN THE U.S.A.!**
41,000 Sq. Ft. indoors, 602 Spaces of Bargains

...featuring: Radio Controlled airplanes, Sailplanes, cars,
boats, control-line airplanes, and related accessories.

The SR-71...How slow could it fly?



EC92-1284-1 Photographed 1992
SR-71 Takeoff



The question I'm most often asked is: "How fast would that SR-71 fly?" I can be assured of hearing that question several times at any event I attend. It's an interesting question, given the aircraft's proclivity for speed. But there really isn't a single number to give as the turbo ramjet would always give you a little more speed. If you wanted it to. It was common to see 35 miles a minute. But we typically flew a programmed Mach number. But because we never wanted to harm the plane in any way, we never let it run 'out' to any limits of temperature or speed. Thus, each SR-71 pilot had his own personal 'high' speed that he saw at some point during our missions. I saw my highest speed over Libya when Khadafy fired two missiles my way and max power was in order. Let's just say that the Blackbird truly loved speed and effortlessly took us to high Mach numbers we had not previously seen.

So it was with great surprise, when at the end of one of my presentations, someone asked: "What was the SLOWEST you ever flew the Blackbird?" This was a first. After giving it some thought, I was reminded of a story that I had never shared before, and relayed the following: I was flying the SR-71 out of RAF Mildenhall, England, with my backseater, Walt Watson. We were returning from a mission over Europe and the Iron Curtain when we received a radio transmission from home base.

As we scooted across Denmark in three minutes, we learned that a small RAF base in the English countryside had requested an SR-71 fly-past. The Commander of air cadets there was a former Blackbird pilot. I thought it would be a motivating moment for the young lads to see the mighty SR-71 perform a low approach. No problem, we were happy to do it. After a quick aerial refueling over the North Sea, we proceeded to find the small airfield. In the back seat, Walter had a myriad of sophisticated navigation equipment and he began to vector me toward the field. Descending to subsonic, we found ourselves over a densely wooded area in the slight haze.

Like most former WWII British airfields, the one we were looking for had a small tower and little surrounding infrastructure. Walter told me we were close. And that I should be able to see the field. But as far as I could see in the haze I saw nothing but trees. We got a little lower, and I pulled the throttles back from our 325 knot cruise. With the gear up anything under 275 knots was plain uncomfortable. Walt said we're practically over the field. Looking hard, there was nothing in my windscreen. I banked the jet and started a gentle circling maneuver, hoping to pick up anything that looked like a field. Meanwhile, below, the Commander had taken the Cadets up on the control tower's catwalk to get a prime view. It was a quiet, still day with no wind and partial gray overcast. Walter continued to give me indications that the field should be below us. But in the overcast and haze, I couldn't see it. But the longer we continued to circle and peer out, the slower we got. With our power back, the awaiting cadets had silence. I must have had good instructors in my flying career, as something told me I better cross-check the gauges.

As I noticed the airspeed indicator s-l-i-d-e below 160 knots. My heart stopped as my adrenalin-filled left hand shoved both throttles FULL FORWARD! At this point we weren't really flying, but were falling in a slight bank. Just at the moment both afterburners lit with a thunderous roar of flame and what a joyous feeling that was as the aircraft fell into full view of the shocked observers on the catwalk. Shattering the absolute quiet of that morning, they now had 107 feet of fire-breathing titanium in their faces as the plane leveled and accelerated, in full burner, on their side of the infield, much closer than expected, maintaining what could only be described as some sort of ultimate knife-edge aerobatic pass.

We proceeded back to Mildenhall without incident, not saying a word to each other for those next 14 minutes. After landing, our commander greeted us and we were both certain he was reaching for our wings. Instead, he heartily shook our hands and said the Commander had told him it was the greatest SR-71 fly-past he had ever seen. Especially how we had surprised them with such a precise maneuver that could only be described as... breathtaking. Some of the cadet's hats were blown off. The sight of the plan form of the plane in full afterburner, dropping right in front of them, was stunning. Unbelievable. Walt and I both understood the concept of "breathtaking" very well that morning. And we sheepishly replied that the Cadets seemed just excited to see our low approach.

As we retired to the equipment room to change from space suits to flight suits, we just sat there. We hadn't spoken a word since the pass. Finally, Walter looked at me and said, "I saw One hundred fifty-six knots. What did you see?" Trying to find my voice I stammered, "One hundred fifty-two." We sat in silence for a moment. Then Walt calmly said, "Don't ever do that to me again." And I never did.

A year later, Walter and I were having lunch in the Mildenhall Officer's club, and overheard an officer talking to some cadets about an SR-71 fly-past that he'd seen one day. Of course by now the story included kids falling off the tower and screaming as the heat of the jet singed their eyebrows. As we stood there with lunch trays in our hands, the officer noticed our HABU shoulder patch icon of a deadly snake asked us to verify to the Cadets that such an event occurred. Walt just shook his head and said, "It was probably just a routine low approach. They're pretty impressive in that airplane." Impressive indeed! Little did I realize that low speed experience would become one of the most requested of my stories? It's ironic that people now became very interested in how slow the world's fastest jet aircraft can fly. Regardless of your speed it's always a good idea to keep up your instrument cross check. I'm certain you'll agree. However keep your Mach up, too.

Fly with the SR-71 <http://www.bbc.com/future/story/20130701-flying-the-worlds-fastest-plane>

Membership Renewal For 2014

Membership renewal for 2013 is now required. You can renew by mail or at the club meeting in December.

Don't loose your club privileges!

Bring cash or check and your AMA card.

Dues are \$60.

Please send a check to;

Ray Wopatek
1004 Green Lane
Secane, PA. 9018

Please enclose a **copy** of your current
A. M. A. Membership card,

**And Please, Please enclose a
Stamped self- addressed envelope.**

Ray Wopatek Membership

Get That?

At the Meeting:

Cash or Check for \$60

AMA Card showing you are paid up.

By Mail:

Cash or Check for \$60

COPY of Your AMA Card showing you are paid up.

Enclose Stamped Self-addressed envelope.